

ES4018 Tested and certified tooling

Ensuring your tooling is up to date and certified



Engineered solution purpose

This engineered solution has been introduced to ensure that the safety requirements for the installation and repair of all Rolls-Royce equipment are current.

Applicability

All Rolls-Royce equipment

Technical description

Test and certify all Rolls-Royce tooling.

Benefits

This engineered solution eliminates any threats to the safety of both equipment and personnel during lifting operations.

Experience

The projects listed below are not an all-inclusive list, but are representative of projects where this upgrade has been applied:

PG&E - 10

TCPL - 5

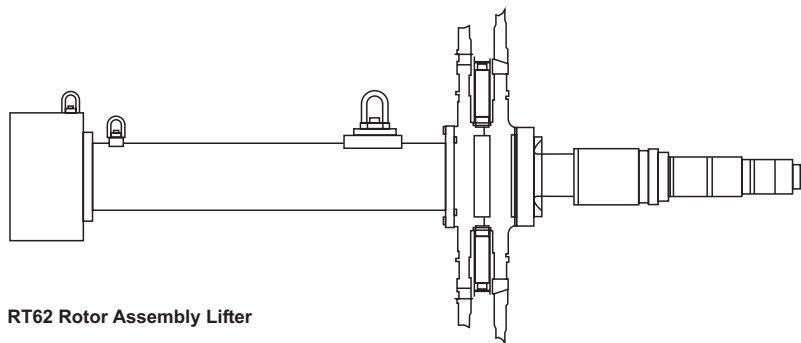

RT62 Rotor Assembly Lifter

Scope of work

Replace older lifting tooling with new tested and certified tooling.

Bill of materials

All lifting tooling

Undertaken

On site

Bundling opportunities

RT48 to RT48S upgrade [\[ES4001\]](#)

RT62/RT56 RB211-24G upgrade [\[ES4013\]](#)

Compressor re-aero [\[ES5001\]](#)

Power turbine overhaul