

## ES4012 RT62 borescope port retrofit

Providing the means for convenient second stage component inspection



### Engineered solution purpose

Borescope ports are installed into the RT62 power turbine to facilitate inspection of the second stage components.

### Applicability

All RT62 power turbines

### Technical description

Borescope ports provide easy access for borescope probes.

### Benefits

The ability to borescope second stage blades and vanes reduces the requirement for power turbine disassembly for the purpose of inspection.

### Experience

Borescope port access is provided for all new production units. One retrofit has been undertaken for PDSVA.

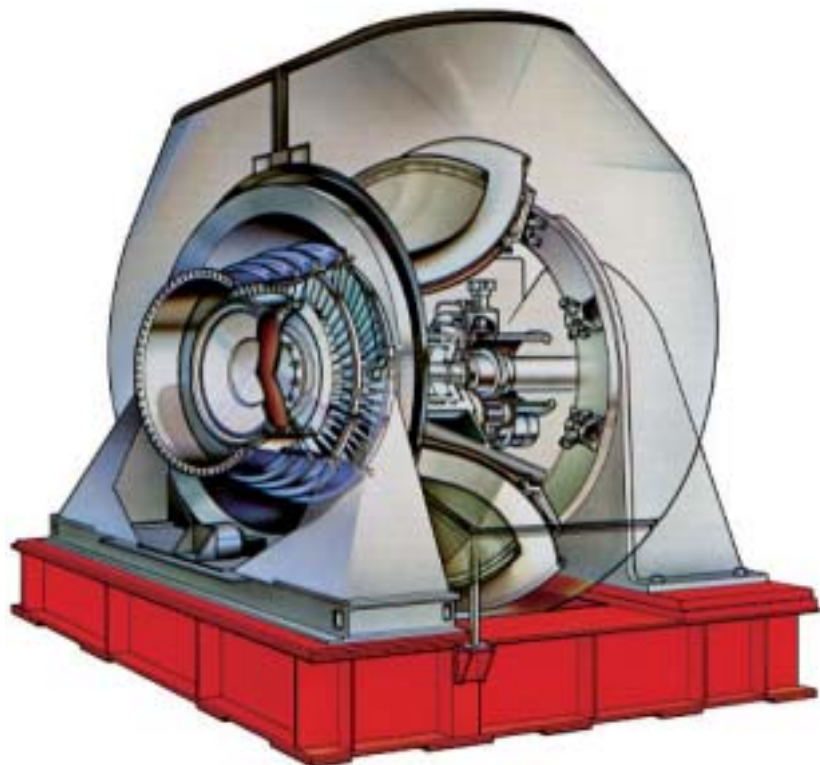

### Scope of work

Ports are provided on the second stage vanes and 4 other vanes.

### Bill of materials

Second stage vane casing and selected vanes

### Undertaken

At site

### Bundling opportunities

Power turbine overhaul

RT62 RB211-24G rating upgrade  
[ES4013]

RT62 rotor tip seal upgrade  
[ES4007]